

ENTS: Experiences in Co-Designed Environmental Sensing

2026 SenSys

Successful Wireless Sensor Networks (WSNs)



ZebraNet

Successful Wireless Sensor Networks (WSNs)

Collaboration with biologists



ZebraNet

Successful Wireless Sensor Networks (WSNs)

Collaboration with biologists



ZebraNet

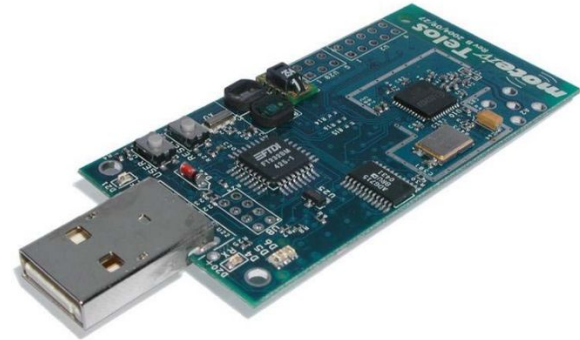

Telos

Successful Wireless Sensor Networks (WSNs)

Collaboration with biologists



ZebraNet

Easy to use, *extensible*

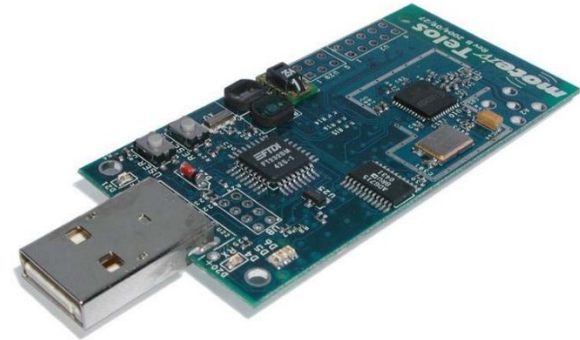

Telos

Other WSNs



Pible

Other WSNs



Pible

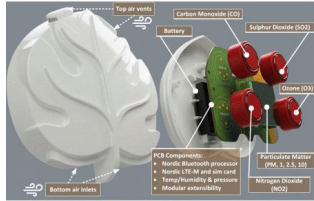

Eclipse

Other WSNs



Pible

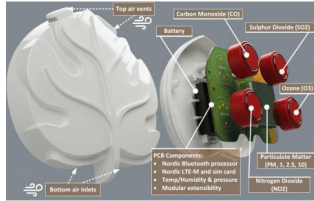

Eclipse

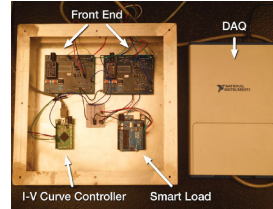

Ekho

Other WSNs



Pible

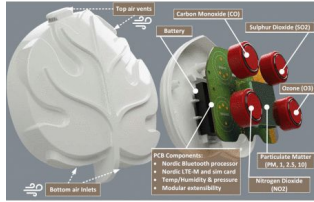

Eclipse

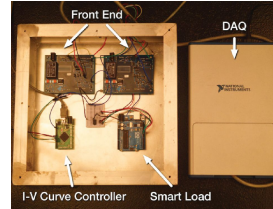

Ekho

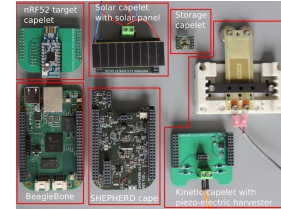

Shepherd

Other WSNs



Pible

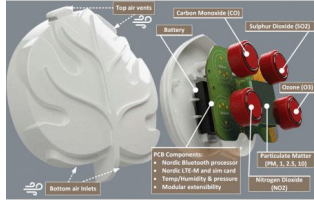

Eclipse

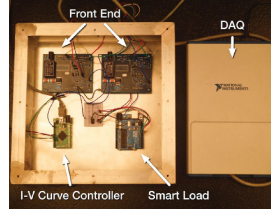

Ekho

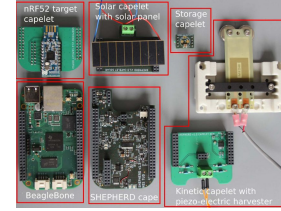

Shepherd

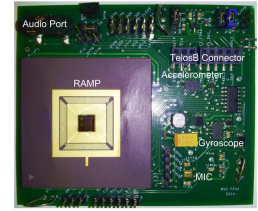

RAMP

Other WSNs



Pible

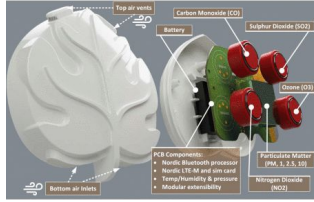

Eclipse

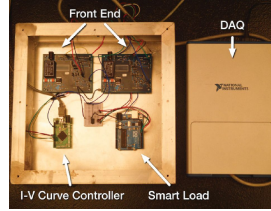

Ekho

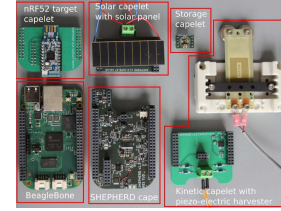

Shepherd

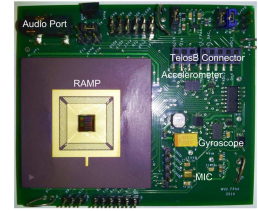

RAMP



Signpost

Other WSNs



Pible

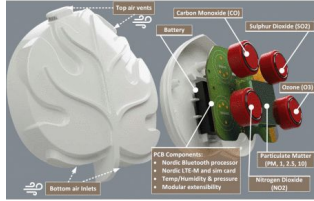

Eclipse

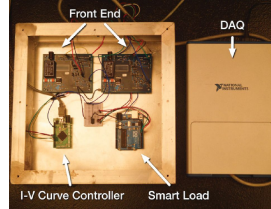

Ekho

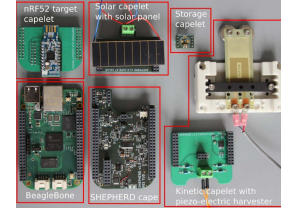

Shepherd

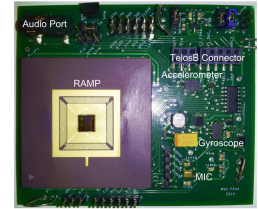

RAMP



Signpost



Firestorm

Other WSNs



Pible

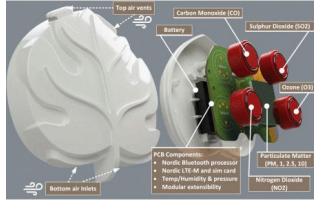

Eclipse

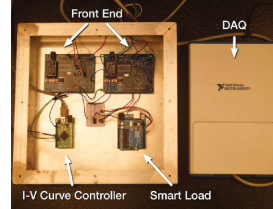

Ekho

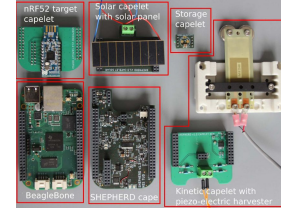

Shepherd

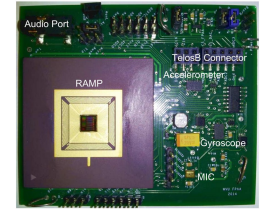

RAMP



Signpost



Firestorm

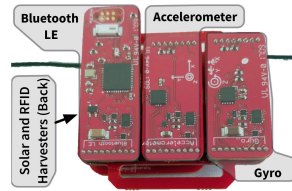

Flicker

Other WSNs



Pible

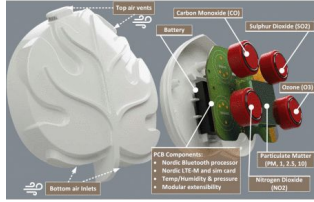

Eclipse

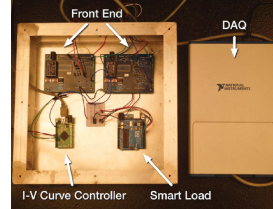

Ekho

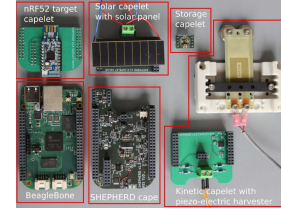

Shepherd

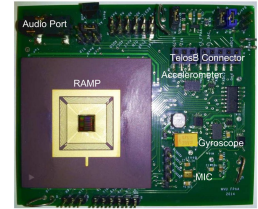

RAMP



Signpost



Firestorm

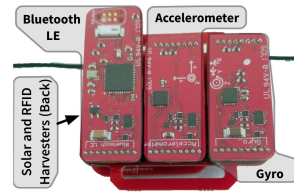

Flicker

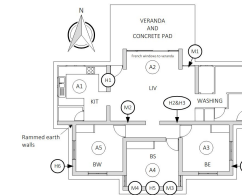

BuildSense

Other WSNs



Pible

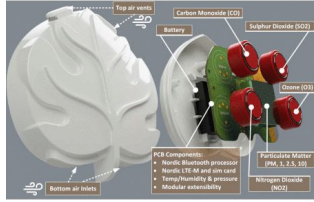

Eclipse

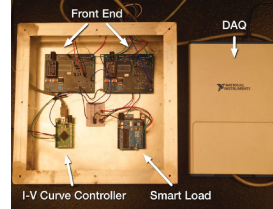

Ekho

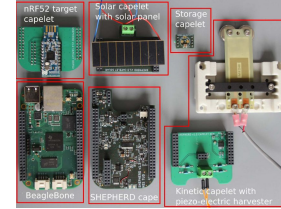

Shepherd

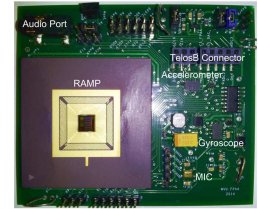

RAMP



Signpost



Firestorm

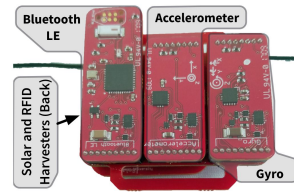

Flicker

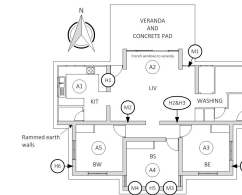

BuildSense

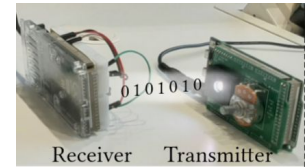

T-light

Environmental NeTworked Sensing (ENTS)

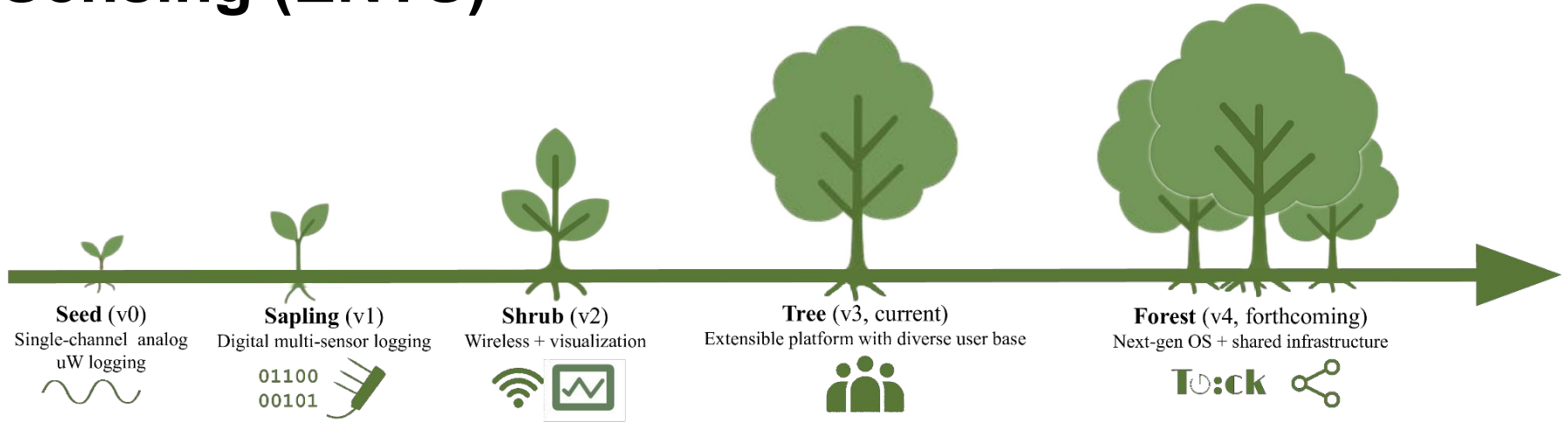

Environmental NeTworked Sensing (ENTS)

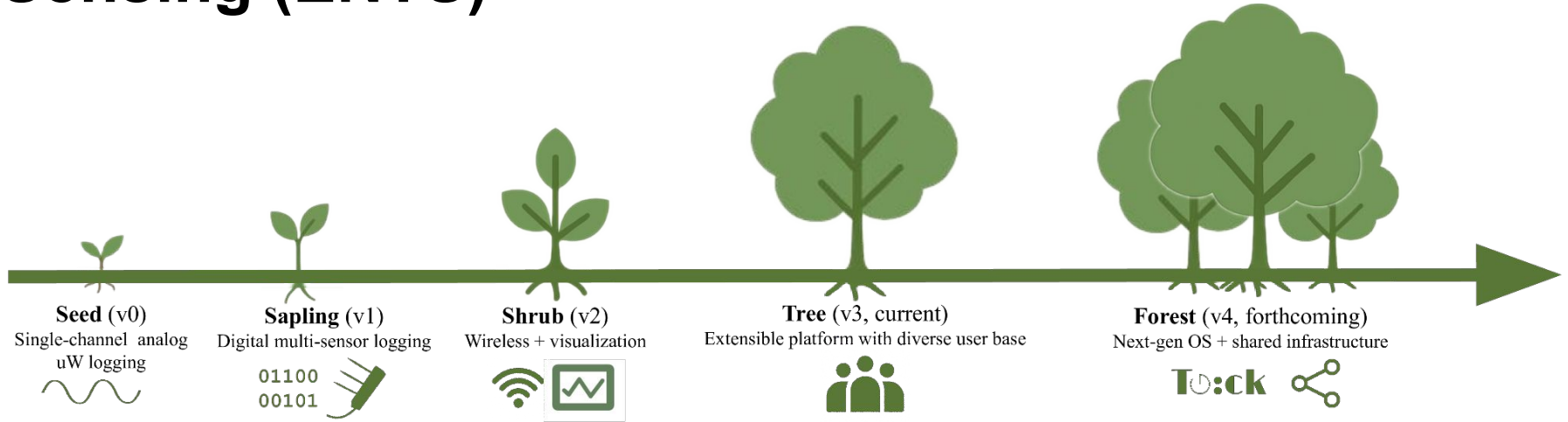

Design principles:

1 Design for breadth

Environmental NeTworked Sensing (ENTS)

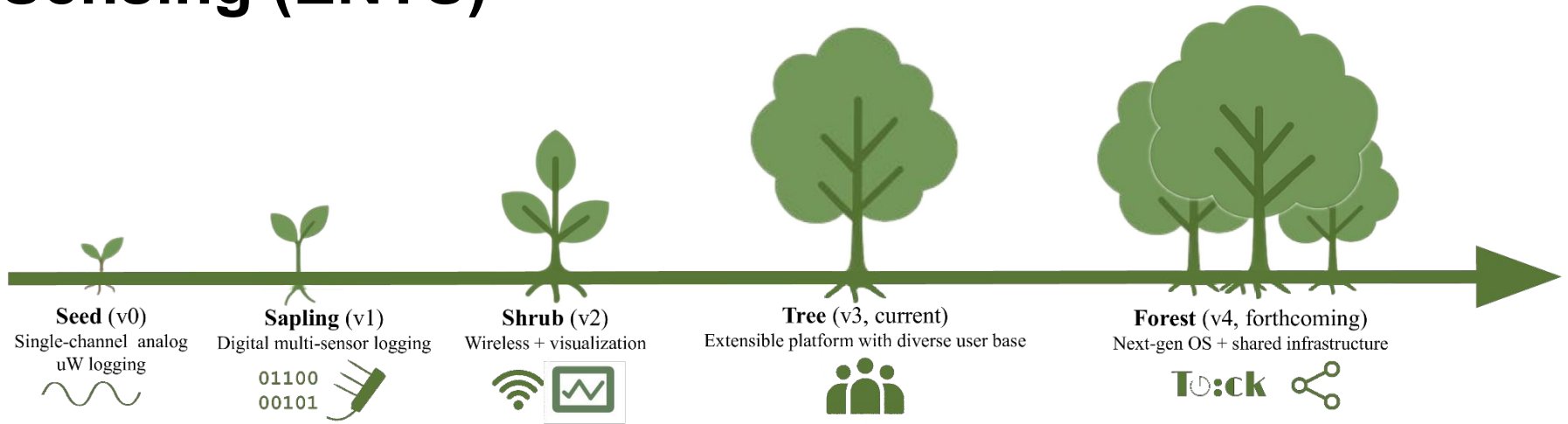

Design principles:

1 Design for breadth

2 Extensibility

Environmental NeTworked Sensing (ENTS)

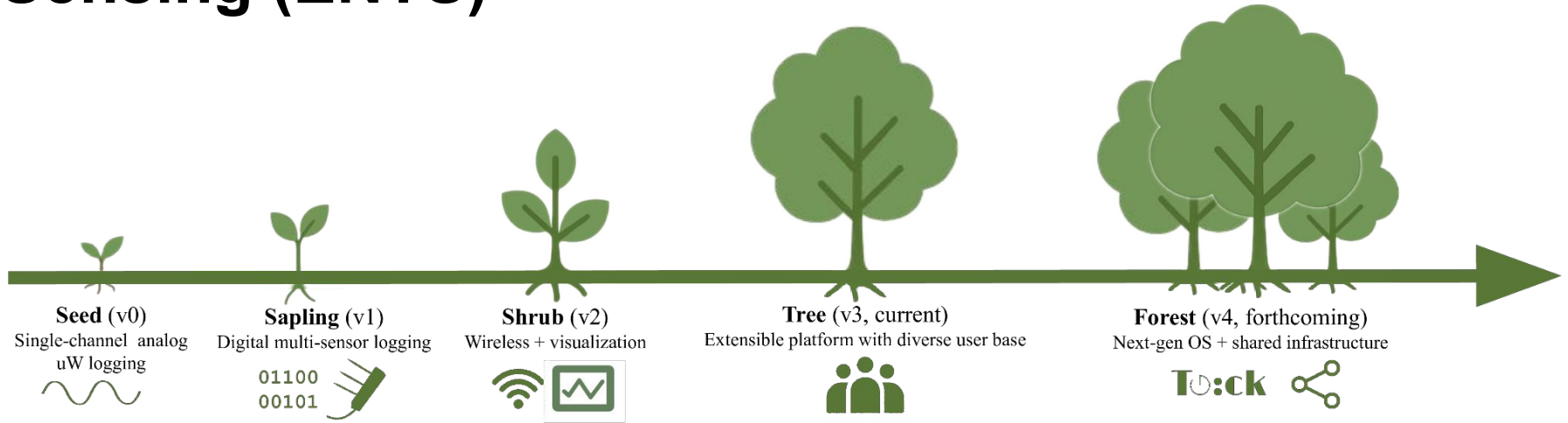

Design principles:

1 Design for breadth

2 Extensibility

3 Co-design and outreach

Applications



Large scale dataset collection of SMFCs

4 universities, 72 cells, year long experiment



Applications



Large scale dataset collection of SMFCs

4 universities, 72 cells, multiple months of data

Biomimetic leaf wetness sensor

Researching disease mitigation in agriculture



Applications



Large scale dataset collection of SMFCs

4 universities, 72 cells, multiple months of data

Biomimetic leaf wetness sensor

Researching disease mitigation in agriculture

Power output from prickly pear cacti

Enabled field deployments with wireless data collection

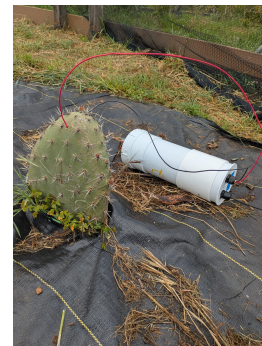

Applications



Large scale dataset collection of SMFCs

4 universities, 72 cells, multiple months of data

Biomimetic leaf wetness sensor

Researching disease mitigation in agriculture

Power output from prickly pear cacti

Enabled field deployments with wireless data collection

Demonstration irrigation site

Application showcasing extensibility



Applications



Large scale dataset collection of SMFCs

4 universities, 72 cells, multiple months of data

Biomimetic leaf wetness sensor

Researching disease mitigation in agriculture

Power output from prickly pear cacti

Enabled field deployments with wireless data collection

Demonstration irrigation site

Application showcasing extensibility

Open Source Community

Facilitate continued growth of the platform



Metric	Hardware	Firmware	Visualization
Internal Contributors	6	7	10
External Contributors	0	2	5
Commits	404	1259	1158
Forks	0	4	18



Use case: μW level power measurements

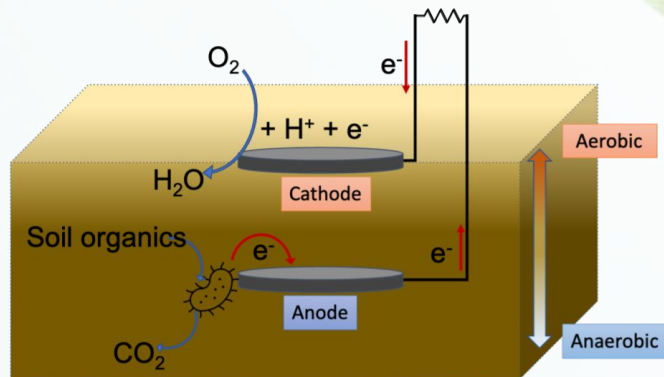

Power generation from soil

Seed (v0)

Sapling (v1)

Shrub (v2)

Tree (v3)

Forest (v4)



Use case: μW level power measurements

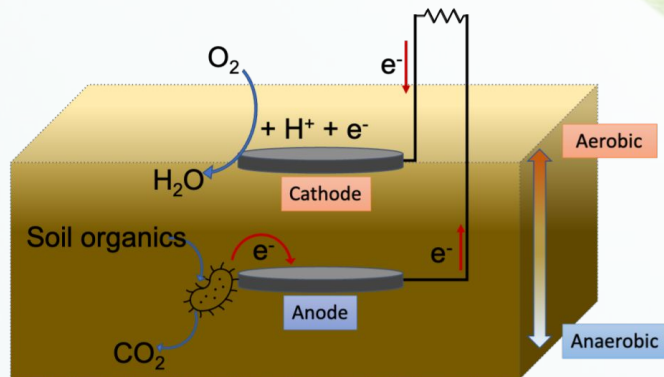

Keithley DAQ6510

Power generation from soil

Seed (v0)

Sapling (v1)

Shrub (v2)

Tree (v3)

Forest (v4)



Use case: μW level power measurements

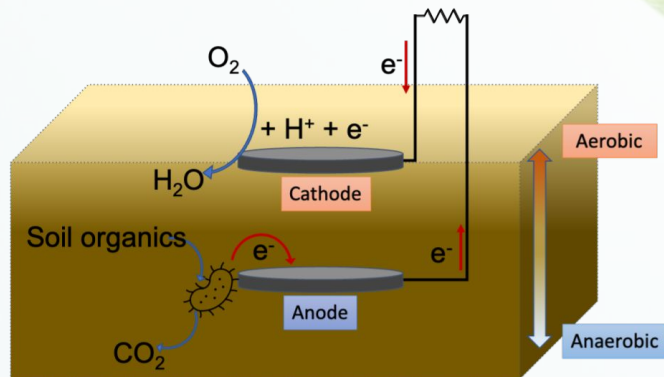

Power generation from soil



Keithley DAQ6510



Seed (v0)

Sapling (v1)

Shrub (v2)

Tree (v3)

Forest (v4)

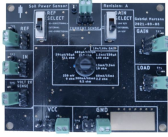

Use case: μW level power measurements

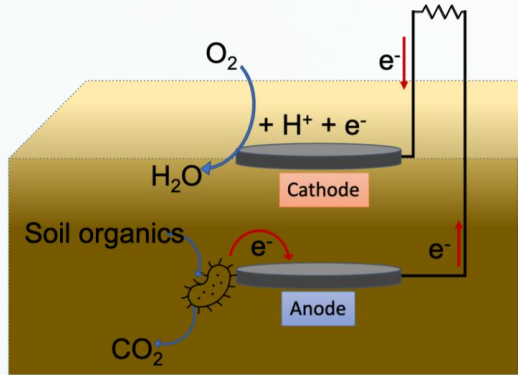

Power generation from

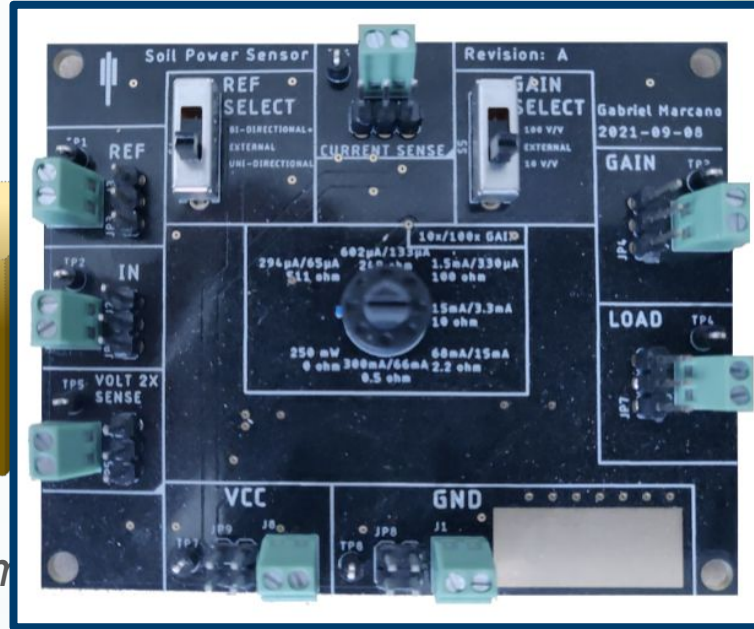

Seed (v0)

Sapling (v1)

Shrub (v2)

Tree (v3)

Forest (v4)



Use case: μW level power measurements

Takeaway: Start by being good at one thing

Power generation from soil

Seed (v0)

Sapling (v1)

Shrub (v2)

Tree (v3)

Forest (v4)

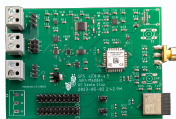

Problem: Hand collected data is slow

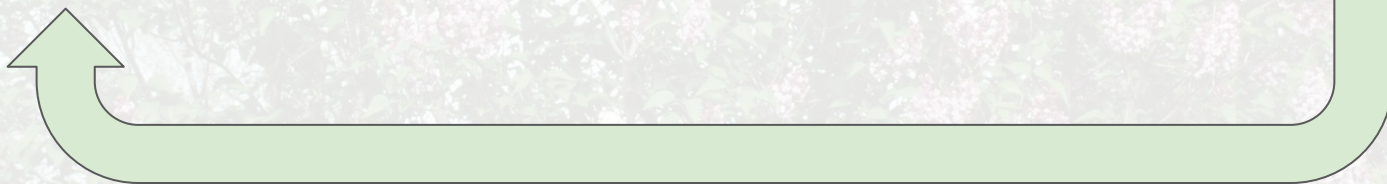
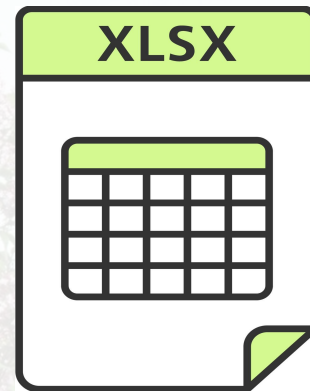
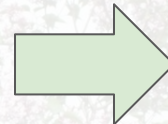
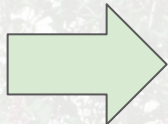
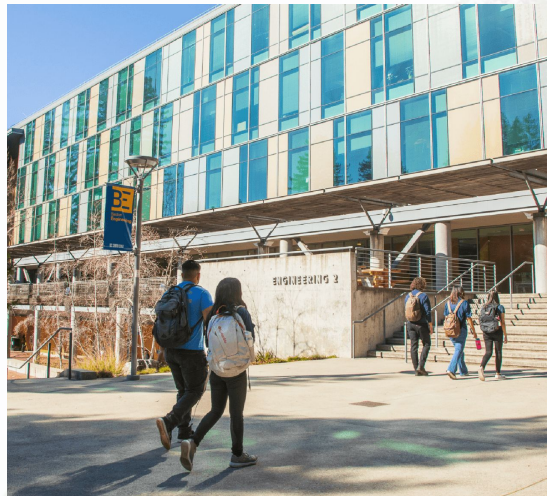

Seed (v0)

Sapling (v1)

Shrub (v2)

Tree (v3)

Forest (v4)





Goal: Enable wireless data collection

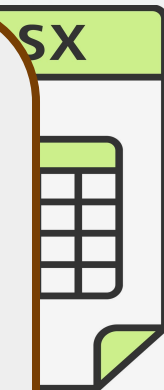
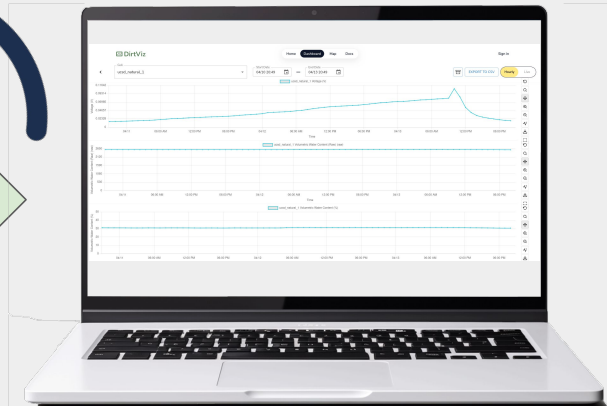

Seed (v0)

Sapling (v1)

Shrub (v2)

Tree (v3)

Forest (v4)



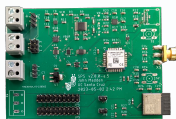

Use case: Biomimetic leaf wetness sensor

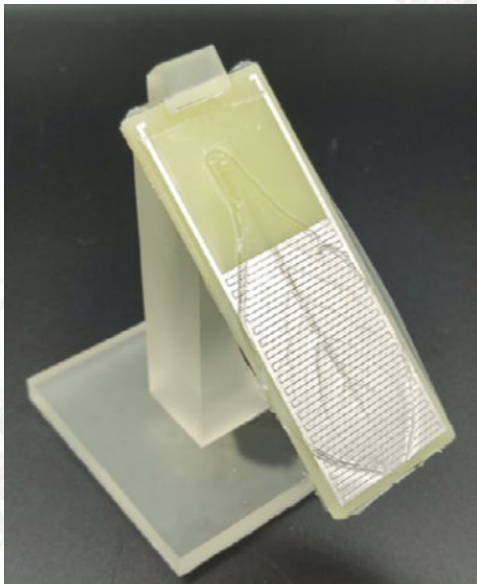

[1] B. H. Nguyen, G. S. Gilbert, and M. Rolandi, "A Bio-Mimetic Leaf Wetness Sensor from Replica Molding of Leaves," *Advanced Sensor Research*, vol. 2, no. 6, p. 2200033, Jun. 2023, doi: [10.1002/adrs.202200033](https://doi.org/10.1002/adrs.202200033).

Seed (v0)

Sapling (v1)

Shrub (v2)

Tree (v3)

Forest (v4)



Use case: Biomimetic leaf wetness sensor

Takeaway: Extensibility drives a platform's longevity.

[1] B. H. Nguyen, G. S. Gilbert, and M. Rolandi, "A Bio-Mimetic Leaf Wetness Sensor from Replica Molding of Leaves," *Advanced Sensor Research*, vol. 2, no. 6, p. 2200033, Jun. 2023, doi: [10.1002/adrs.202200033](https://doi.org/10.1002/adrs.202200033).

Seed (v0)

Sapling (v1)

Shrub (v2)

Tree (v3)

Forest (v4)

Observation: Need for field logging platform

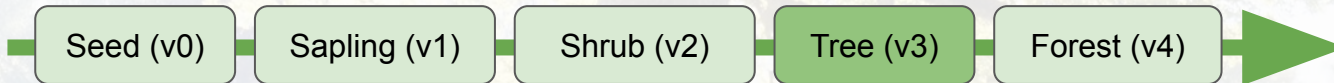
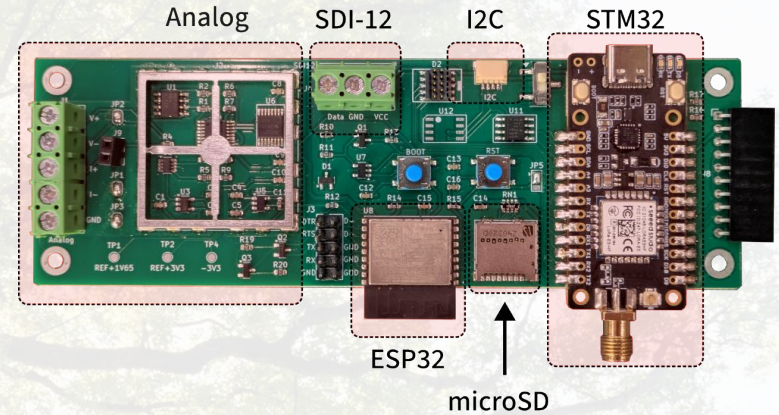
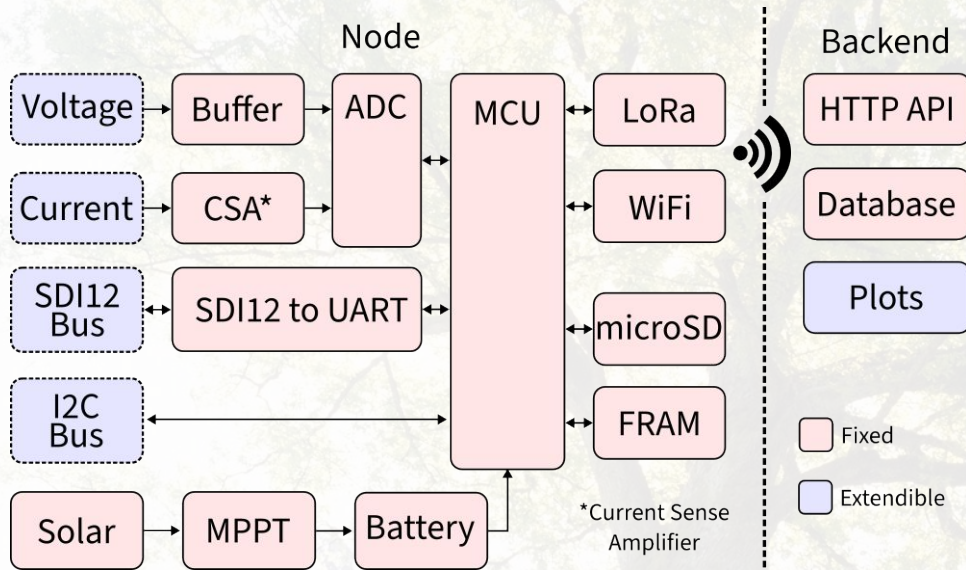



Use case: Energy harvesting from cacti

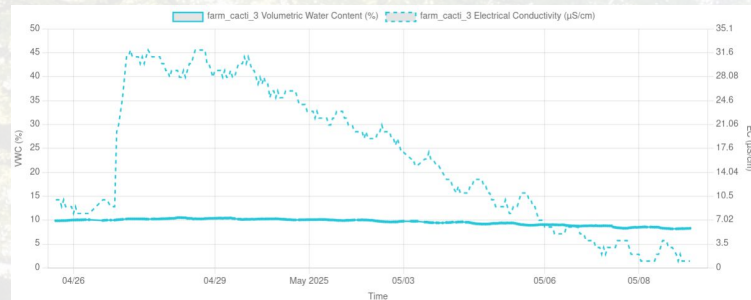
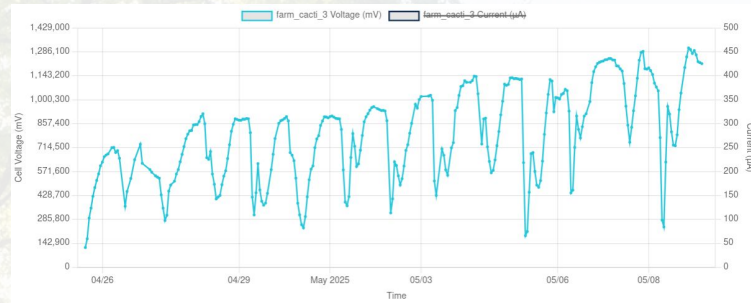

Seed (v0)

Sapling (v1)

Shrub (v2)

Tree (v3)

Forest (v4)



Use case: Energy harvesting from cacti

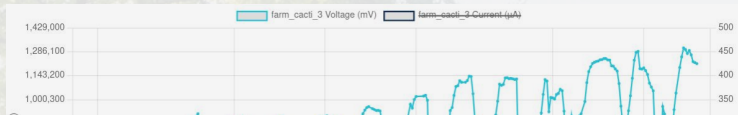

Takeaway: Co-design drives development

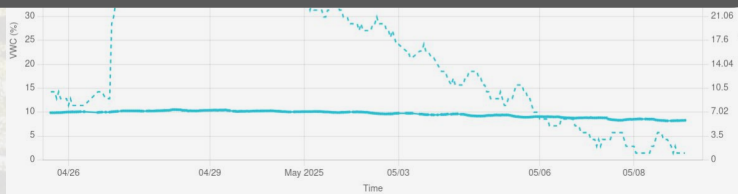

Seed (v0)

Sapling (v1)

Shrub (v2)

Tree (v3)

Forest (v4)



UC SANTA CRUZ

36

ENTS bears fruit: Reasons for success



Open source ecosystem

Contributions from: GSOC, undergradutes, external collaborators.

Metric	Hardware	Firmware	Visualization
Internal Contributors	6	7	10
External Contributors	0	2	5
Commits	404	1259	1158
Forks	0	4	18

ENTS bears fruit: Reasons for success



Open source ecosystem

Contributions from: GSOC, undergradutes, external collaborators.



Design for extensibility

Allowed the project to adapt to various needs over time.

Metric	Hardware	Firmware	Visualization
Internal Contributors	6	7	10
External Contributors	0	2	5
Commits	404	1259	1158
Forks	0	4	18

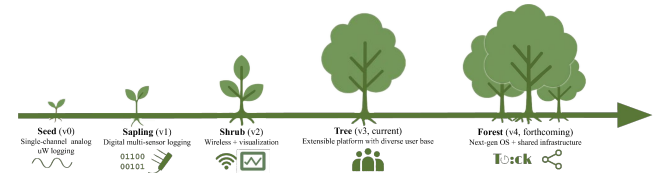

ENTS bears fruit: Reasons for success



Open source ecosystem

Contributions from: GSOC, undergraduates, external collaborators.



Design for extensibility

Allowed the project to adapt to various needs over time.



Domain science partnerships

Informed development efforts and engineering decisions.

Metric	Hardware	Firmware	Visualization
Internal Contributors	6	7	10
External Contributors	0	2	5
Commits	404	1259	1158
Forks	0	4	18

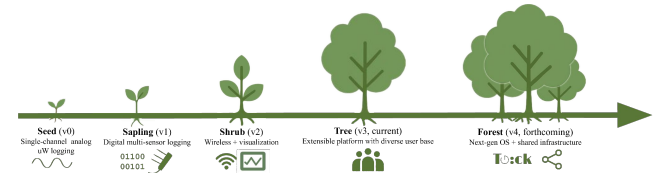

Where to find us

- Josephson Lab Website
<https://sensors.soe.ucsc.edu/>
- John Madden (Me)
<https://www.jmadden173.com/>
- Stephen Taylor (Co-author)
<https://stevegtaylor.github.io/>
- Live Data
<https://dirtviz.jlab.ucsc.edu/>



Project Repos

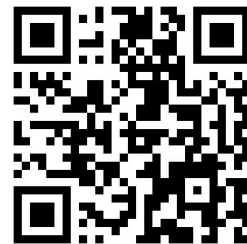

Paper Link

